

F325 Module 2: HW11

1. The table below shows the enthalpy changes needed to calculate the lattice enthalpy of calcium oxide, CaO.

process	enthalpy change/ kJ mol^{-1}
first ionisation energy of calcium	+590
second ionisation energy of calcium	+1150
first electron affinity of oxygen	-141
second electron affinity of oxygen	+ 791
enthalpy change of formation of calcium oxide	-635
enthalpy change of atomisation of calcium	+178
enthalpy change of atomisation of oxygen	+248

- (a) (i) Explain why the second ionisation energy of calcium is **more endothermic** than the first ionisation energy of calcium.

.....
.....
.....

[2]

- (ii) Suggest why the second electron affinity of oxygen is positive.

.....
.....
.....

[2]

(b) Complete the Born–Haber cycle for calcium oxide below.

Use the data in the table to calculate the lattice enthalpy of calcium oxide.

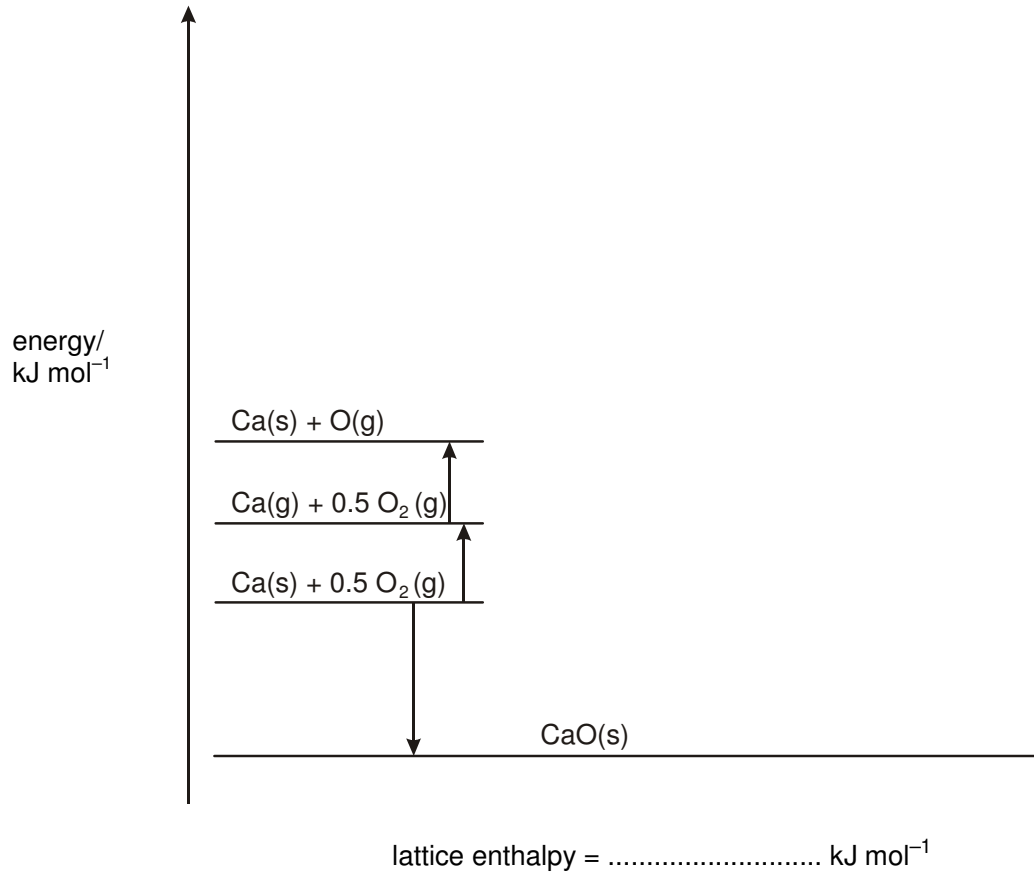

[5]

- (c) The lattice enthalpies of calcium oxide and magnesium oxide are different.

Comment on this difference.

In your answer you should make clear how the sizes of the lattice enthalpies are related to any supporting evidence.

.....

.....

.....

.....

[3]

[Total 12 marks]

2. The table below shows the enthalpy changes needed to construct a Born-Haber cycle for sodium oxide, Na₂O.

process	enthalpy change / kJ mol ⁻¹
first ionisation energy of sodium	+495
first electron affinity of oxygen	-141
second electron affinity of oxygen	+791
enthalpy change of formation for sodium oxide	-416
enthalpy change of atomisation for sodium	+109
enthalpy change of atomisation for oxygen	+247

- (a) Use the table of enthalpy changes to complete the Born-Haber cycle by putting in the correct numerical values on the appropriate dotted line.

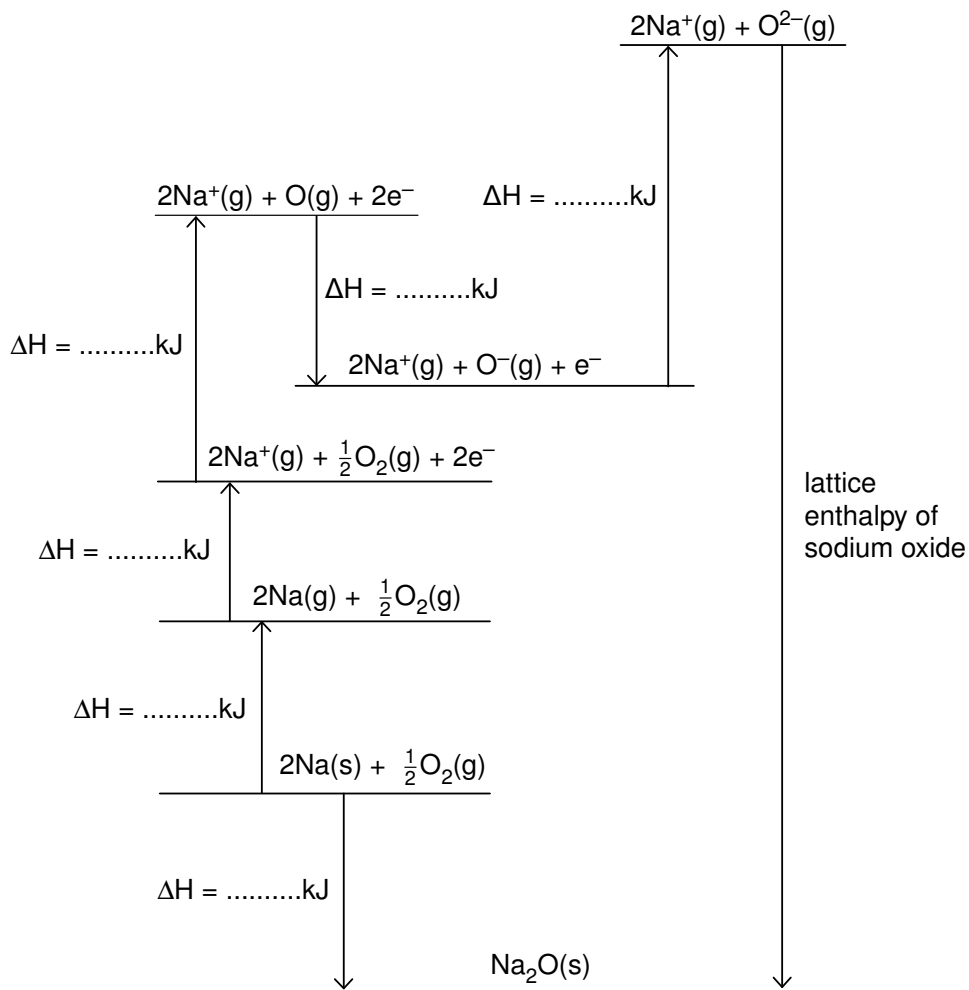

[4]

- (b) Use the Born-Haber cycle to calculate the lattice enthalpy of sodium oxide.

lattice enthalpy =kJ mol⁻¹

[2]

(c) Which one of the following compounds has the most exothermic lattice enthalpy?

- calcium bromide
- calcium chloride
- potassium bromide
- potassium chloride

Explain your answer in terms of the ions present.

.....

.....

.....

.....

.....

.....

.....

.....

[4]

[Total 10 marks]

4. The table below shows the enthalpy changes needed to calculate the lattice enthalpy of calcium chloride, CaCl_2 .

process	enthalpy change / kJ mol^{-1}
first ionisation energy of calcium	+590
second ionisation energy of calcium	+1150
electron affinity of chlorine	-348
enthalpy change of formation for calcium chloride	-796
enthalpy change of atomisation for calcium	+178
enthalpy change of atomisation for chlorine	+122

- (a) The Born-Haber cycle below can be used to calculate the lattice enthalpy for calcium chloride.

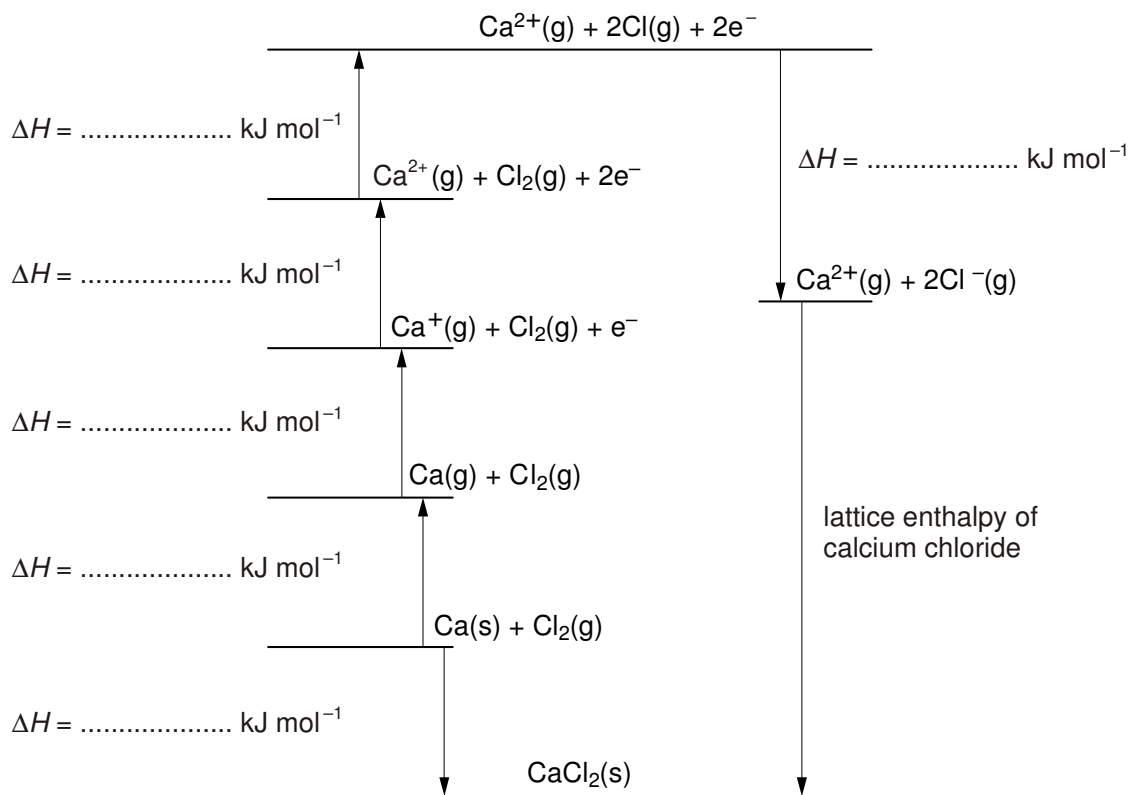

- (i) Use the table of enthalpy changes to complete the Born-Haber cycle by putting in the correct numerical values on the appropriate dotted line.

[3]

F325 Module 2: HW11

- (ii) Use the Born-Haber cycle to calculate the lattice enthalpy of calcium chloride.

answer kJ mol^{-1}

[2]

- (iii) Describe how, and explain why, the lattice enthalpy of magnesium fluoride differs from that of calcium chloride.

.....
.....
.....
.....
.....

[3]

- (b) Explain why the first ionisation energy of calcium is less positive than the second ionisation energy.

.....

.....

.....

.....

.....

.....

[2]

[Total 10 marks]