

Energy HSW Ex HW

How does a torch work?

A torch has a circuit in it. Use the diagram of a torch to describe and explain your ideas about energy and electricity. Use the level ladder below to help you achieve your target.

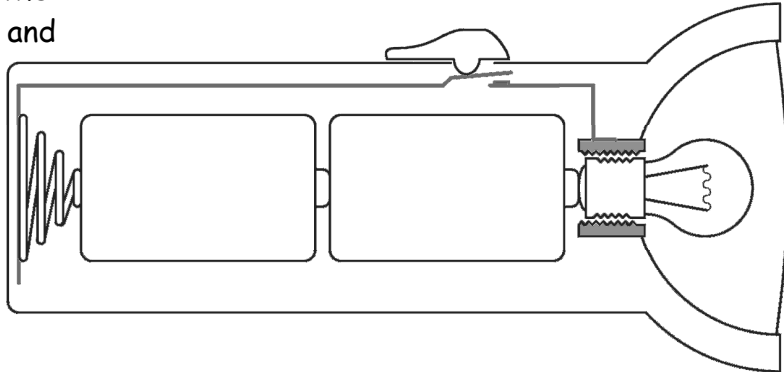

Task:

- Use the diagram above to help you explain how the torch works.
- Draw a circuit diagram of the torch.
- Use a model of an electric circuit to explain how the circuit works.

Key words: battery (cell), bulb, conductor, current, insulator, metal, plastic, switch, voltage, wire

To get level	You might have:
4	<ul style="list-style-type: none"> • Drawn a circuit diagram using standard circuit symbols. • Stated the job of the cells, wires, bulb and switch. • Identified which materials in the torch are conductors and insulators.
5	<ul style="list-style-type: none"> • Drawn a circuit diagram using standard circuit symbols. • Described the job of the cells, wires, bulb and switch. • Described materials in the torch as conductors and insulators.
6	<ul style="list-style-type: none"> • Drawn a circuit diagram using standard circuit symbols. • Explained the job of the cells, wires, bulb and switch. • Drawn a model of electricity to explain how the circuit works, using the terms <i>current</i> and <i>voltage</i> correctly. • Explained why the parts of your model are like the real circuit components. • Described limitations of the model circuit compared to the actual circuit.
7	<ul style="list-style-type: none"> • Drawn a circuit diagram using standard circuit symbols. • Drawn a model of electricity to explain how the circuit works, using the terms <i>current</i> and <i>voltage</i> correctly. • Explained why the parts of your model are like the real circuit components. • Explained limitations of the model circuit compared to the actual circuit. • Used a model of electricity to describe the energy transfers in a circuit.